

# ENGINEERING DRAWING

MAY 19

**OUR CENTERS :**

**KALYAN | DOMBIVLI | THANE | NERUL | DADAR**

**Contact - 9136008228**

Q.1. (a) One end of an elastic string, 125 mm long is attached to the circumference of a circular disc of 50 mm diameter. The free end of the string is wound around the disc, keeping the string always tight. Draw the locus of the free end and name the curve. (06)

SOL:

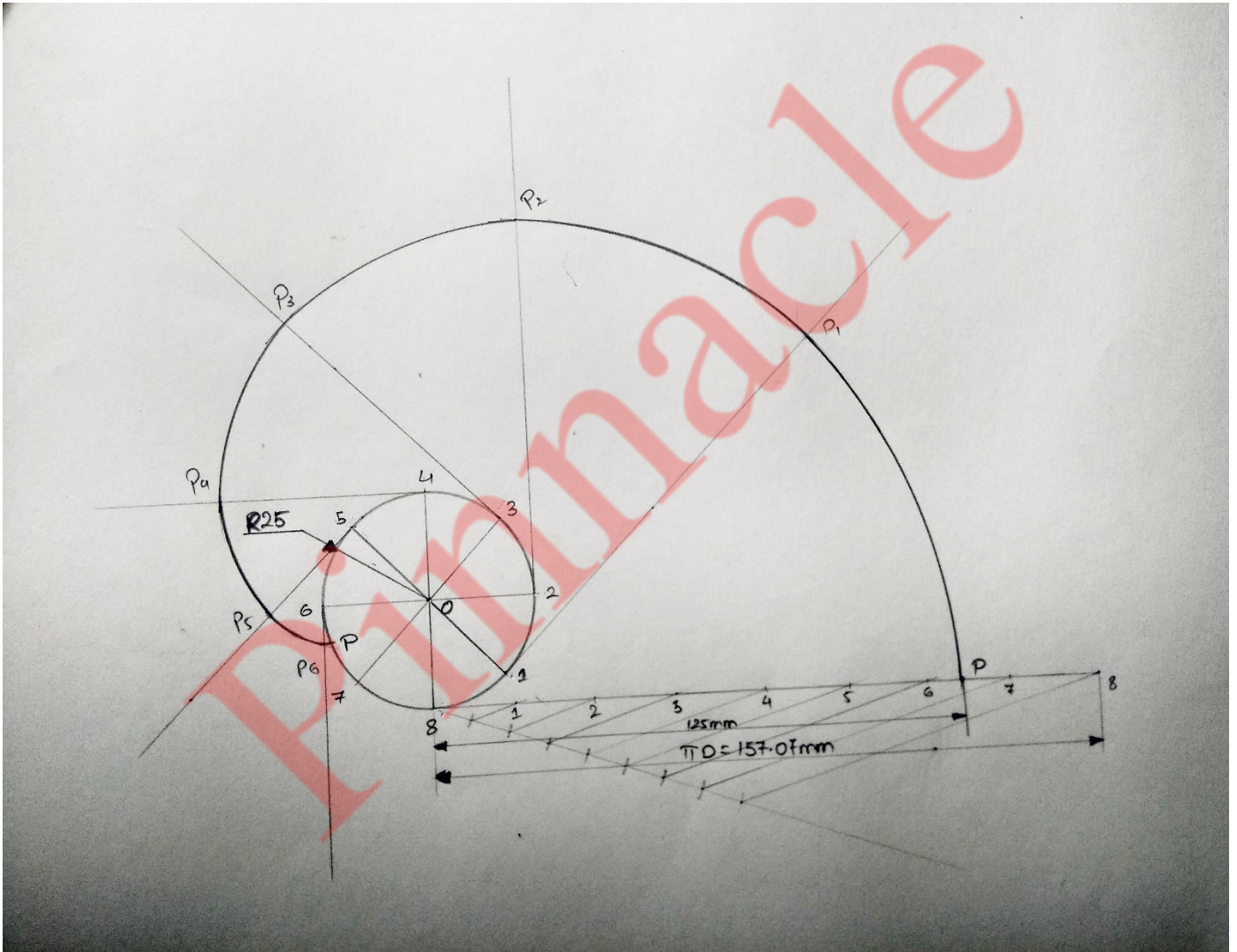

**OUR CENTERS :**

**KALYAN | DOMBIVLI | THANE | NERUL | DADAR**

**Contact - 9136008228**

Q.1. (b) For the object shown in figure draw the following views –

(i) Front view in the direction of arrow X. (05)

(ii) Top view. (04)

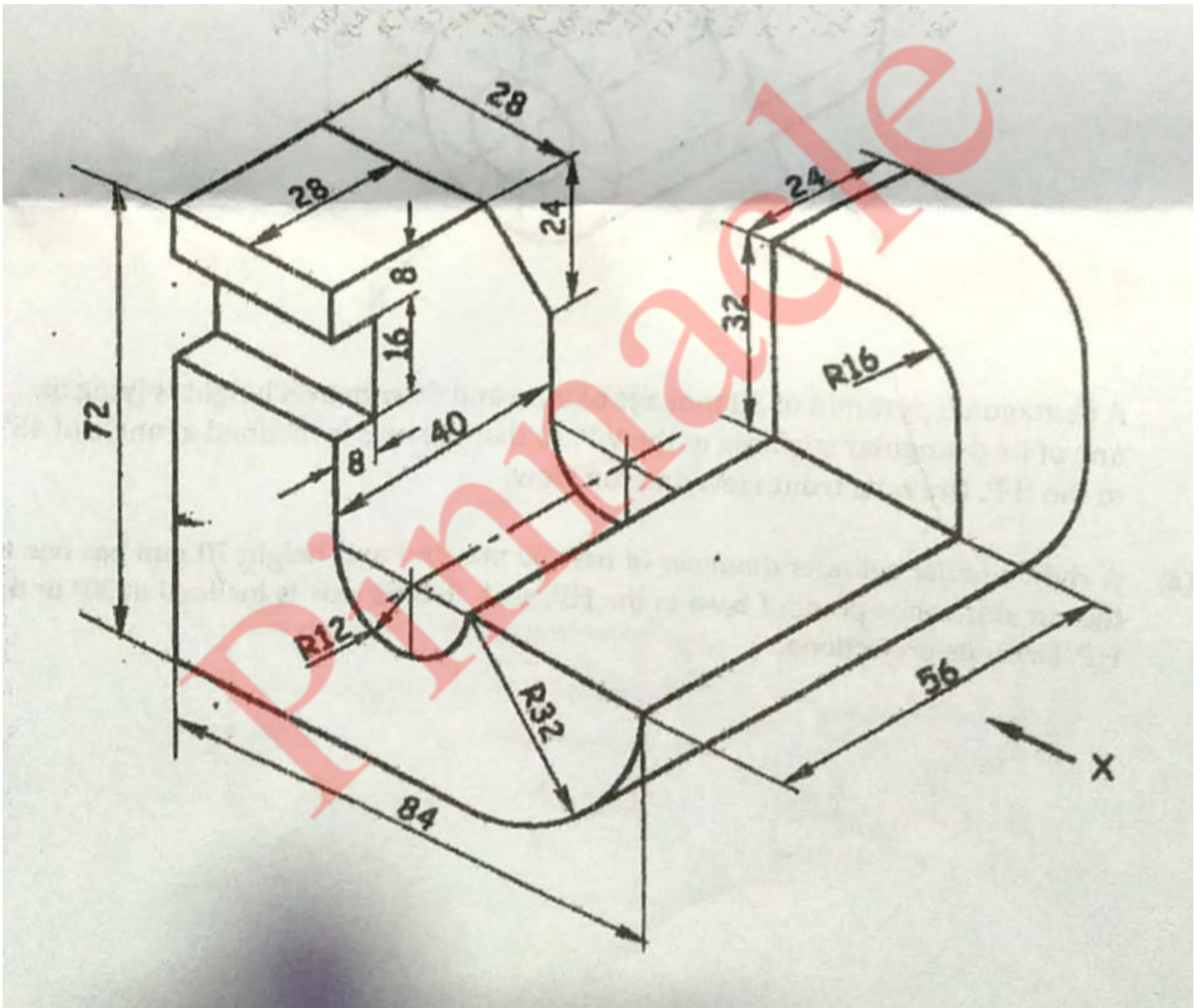

**OUR CENTERS :**

**KALYAN | DOMBIVLI | THANE | NERUL | DADAR**

**Contact - 9136008228**

SOL:

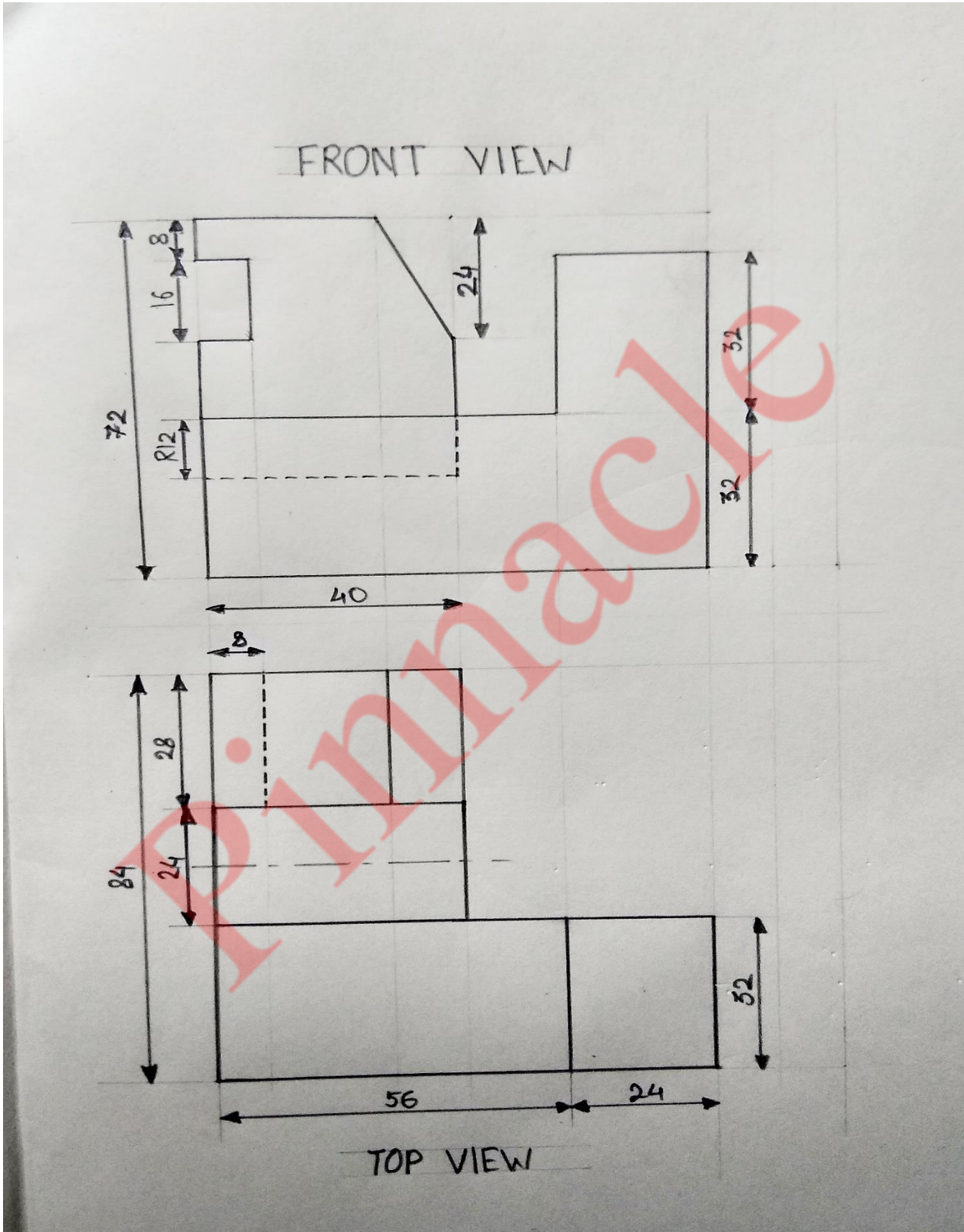

Q.2. For the object shown in figure draw the following views-

- (i) Sectional front view along section A-A. (04)
- (ii) Side view from left (04)
- (iii) Top view (05)
- (iv) Insert the major dimensions. (02)

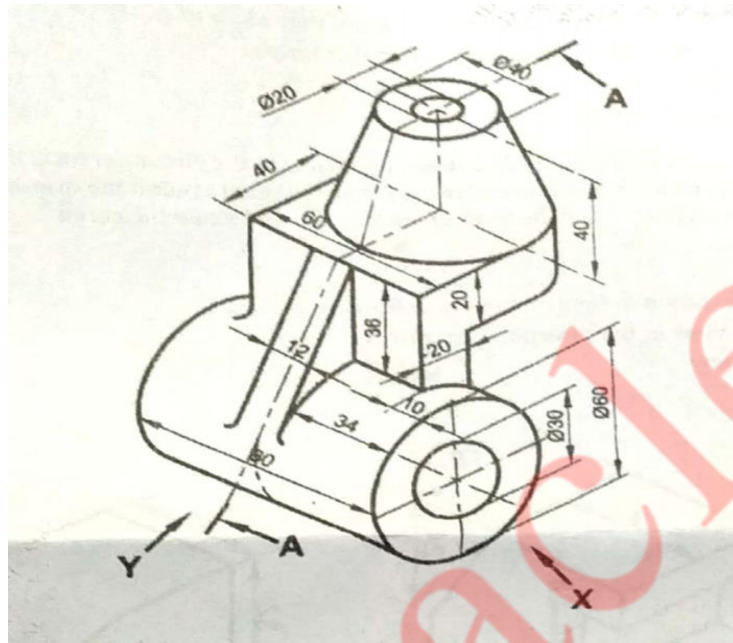

SOL:

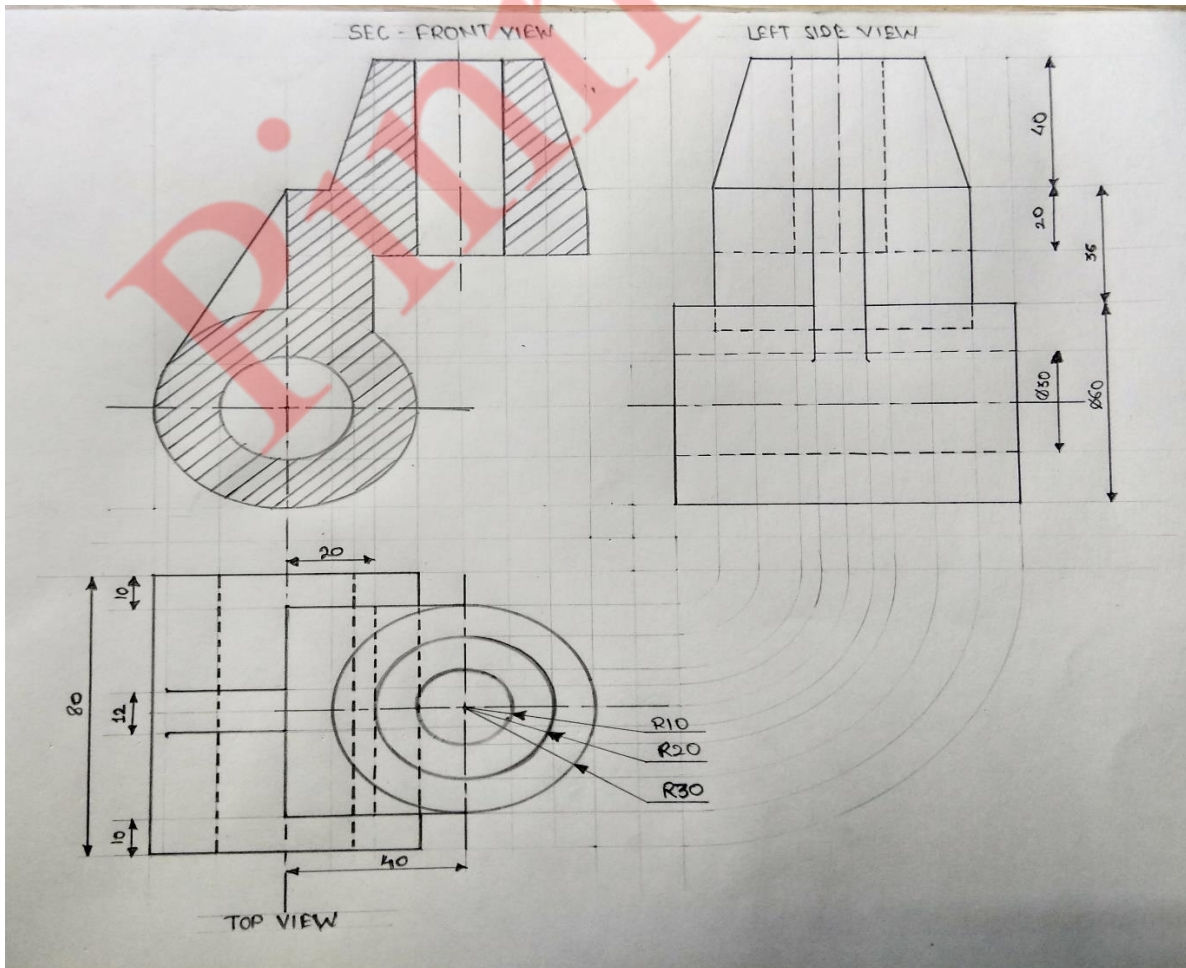

**OUR CENTERS :**

**KALYAN | DOMBIVLI | THANE | NERUL | DADAR**

**Contact - 9136008228**

Q.3 A pentagonal pyramid of 30 mm edge of base and 60 mm axis height is lying on one of its triangular surfaces in the V.P. so that the axis is inclined at angle of  $45^\circ$  to the H.P. Draw its front view and top view. (15)

SOL:

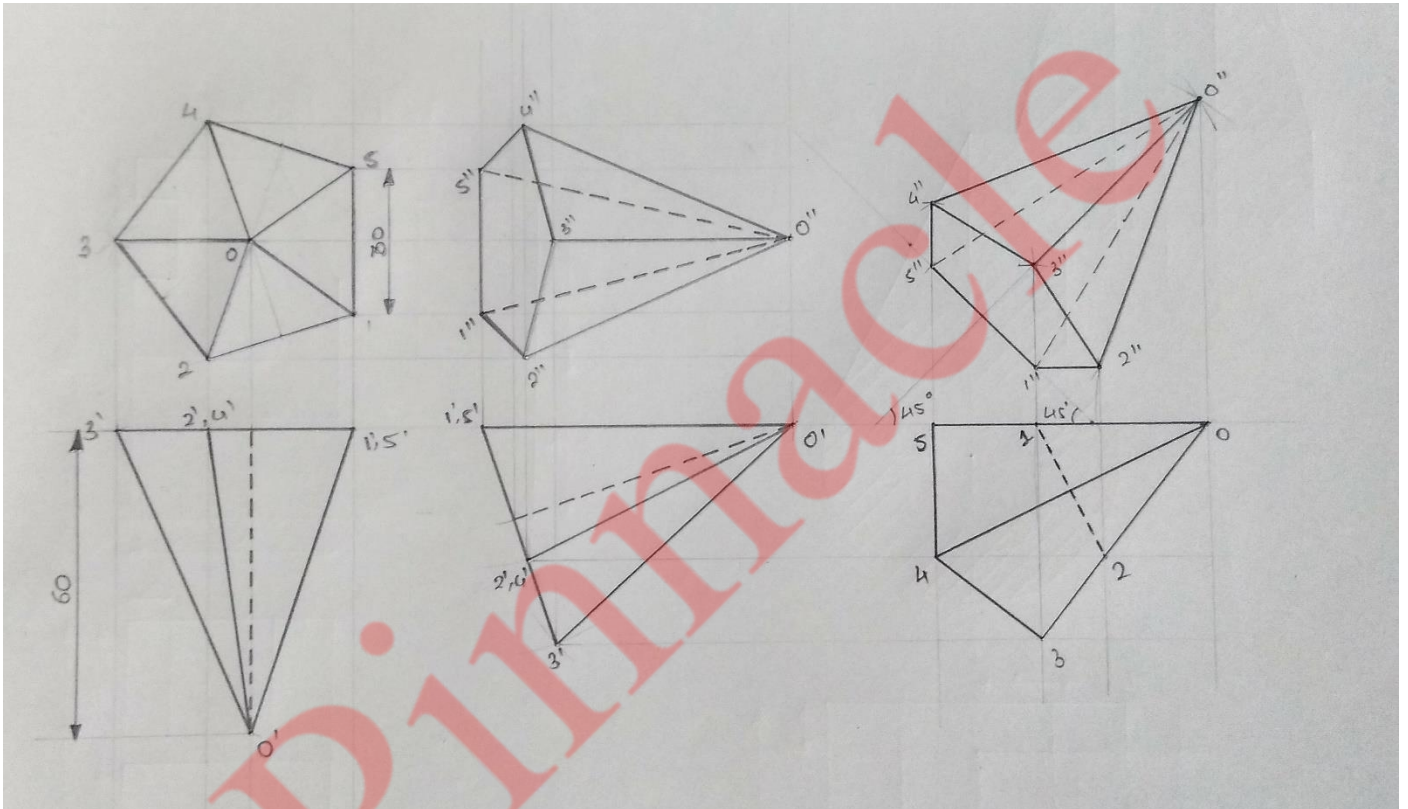

Q.4 (a) A right circular cylinder diameter of base 50 mm and axis height 70 mm has one of the circumference point of base in the HP, such that its axis is inclined at  $30^\circ$  to the HP. Draw its projections. (06)

SOL:

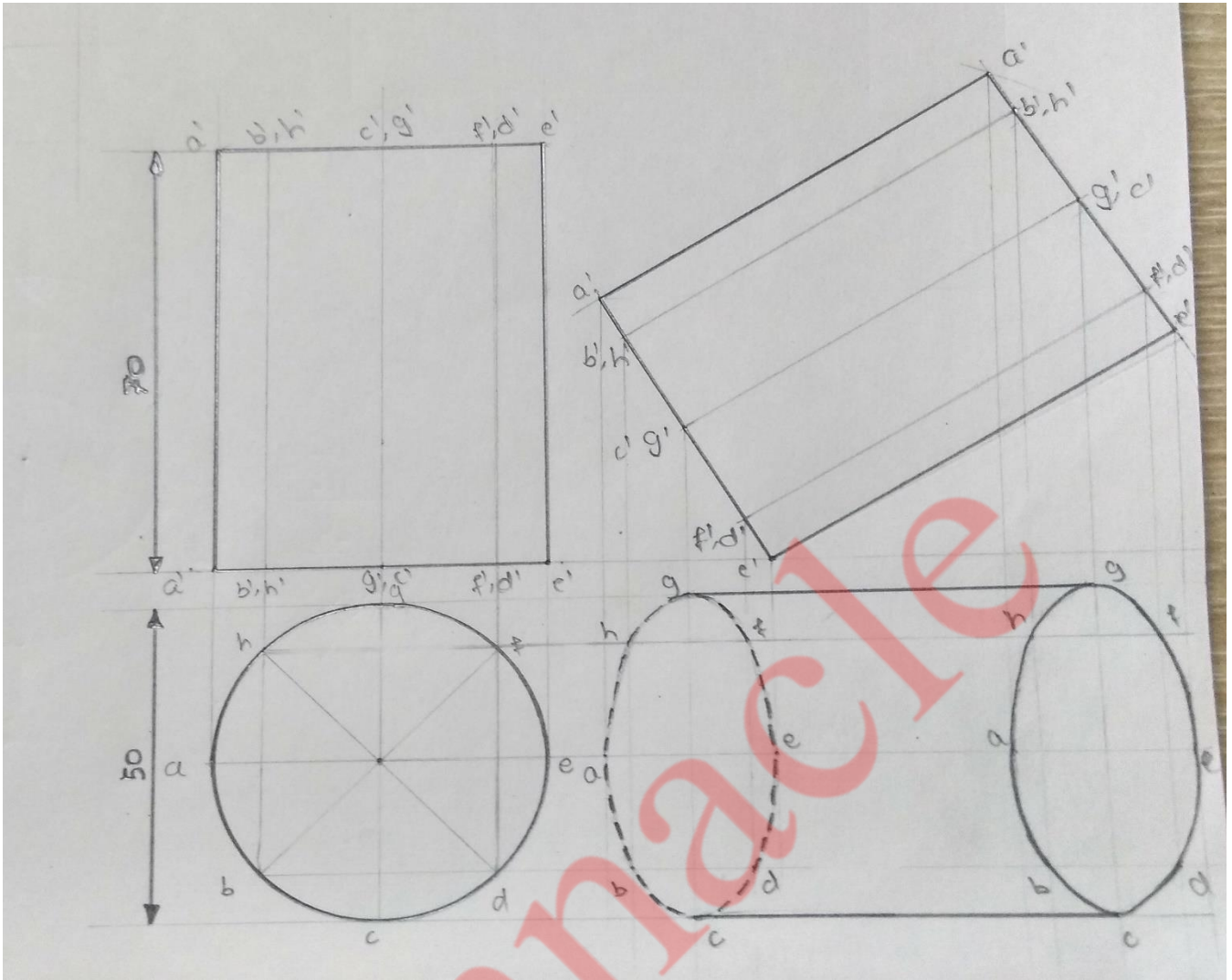

Q.4 (b) Figure shows two views of an object. Draw its isometric view.

(09)

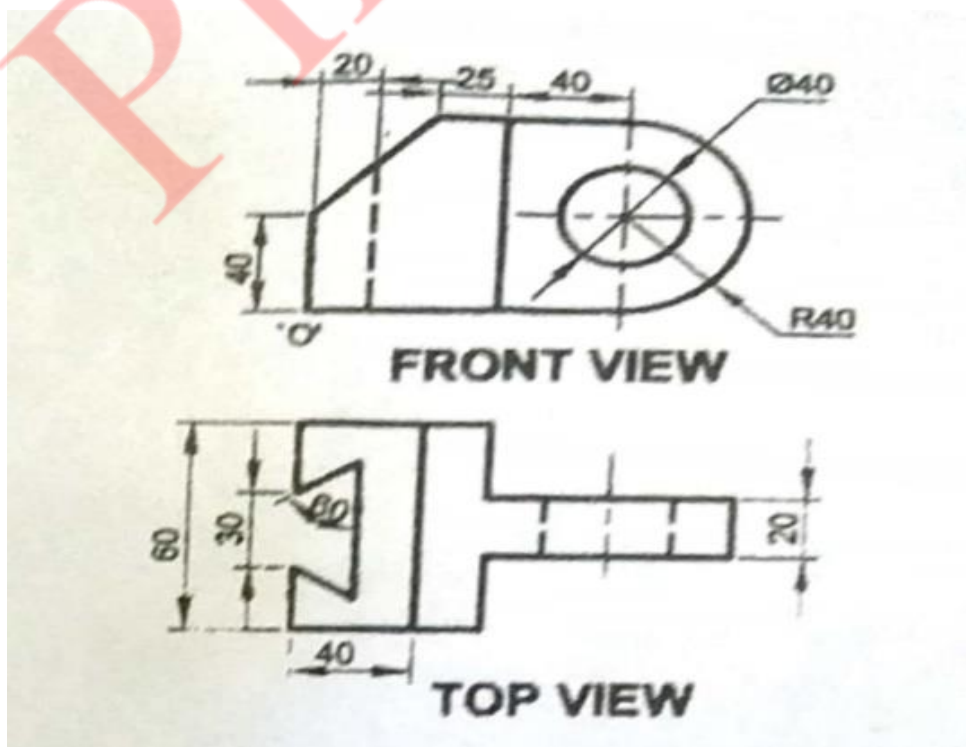

OUR CENTERS :

KALYAN | DOMBIVLI | THANE | NERUL | DADAR

Contact - 9136008228

SOL:

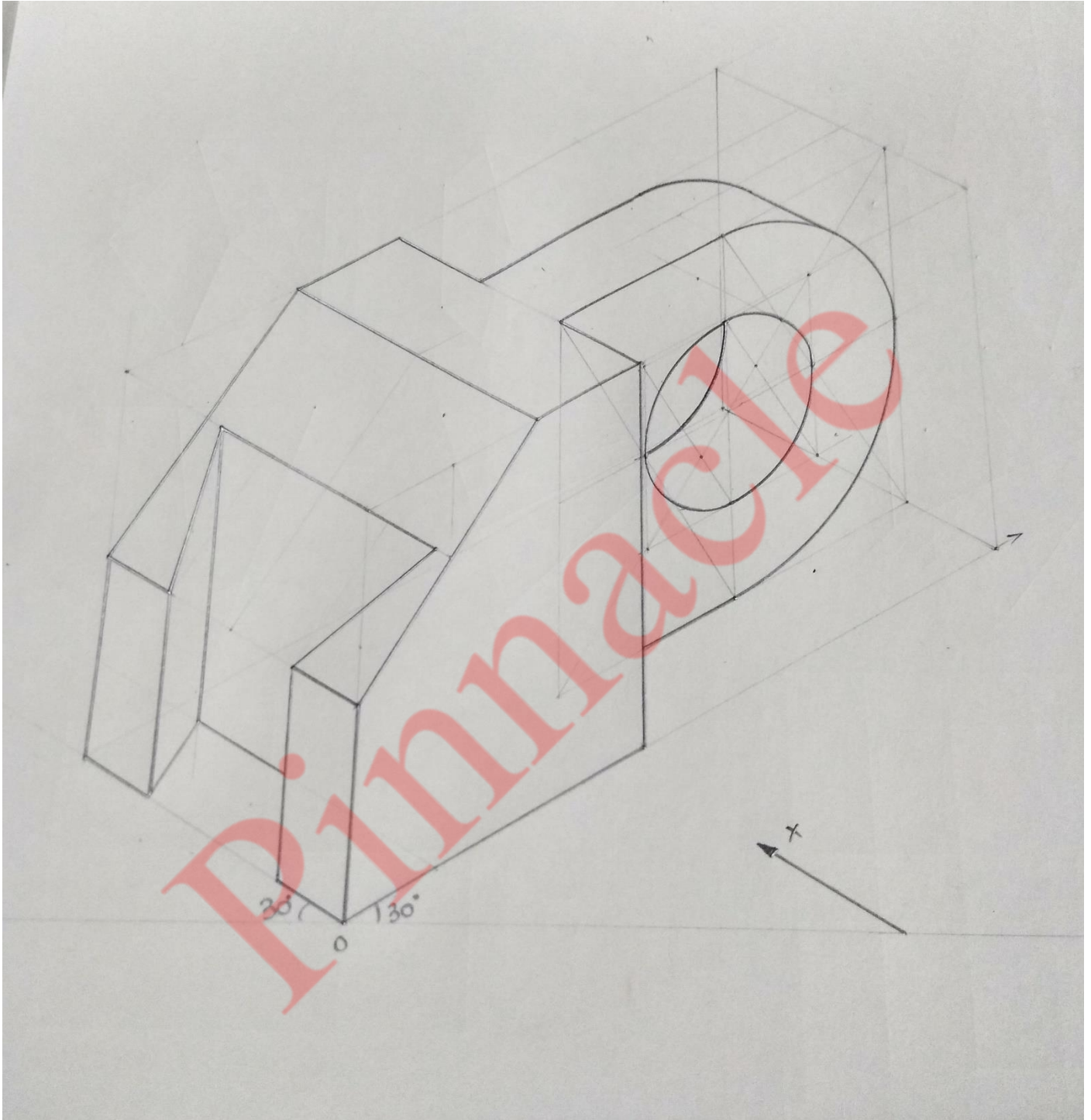

**OUR CENTERS :**

**KALYAN | DOMBIVLI | THANE | NERUL | DADAR**

**Contact - 9136008228**



Q.5 A cone of base 70 mm diameter and axis 90 mm long is resting on its base on HP. It is cut by a section plane perpendicular to the VP and parallel to and 15 mm away from one of its end generators. Draw the sectional top view, front view & sectional side view. Also draw the true shape of the section. Also draw development of the lateral surface of the cone. (15)

SOL:

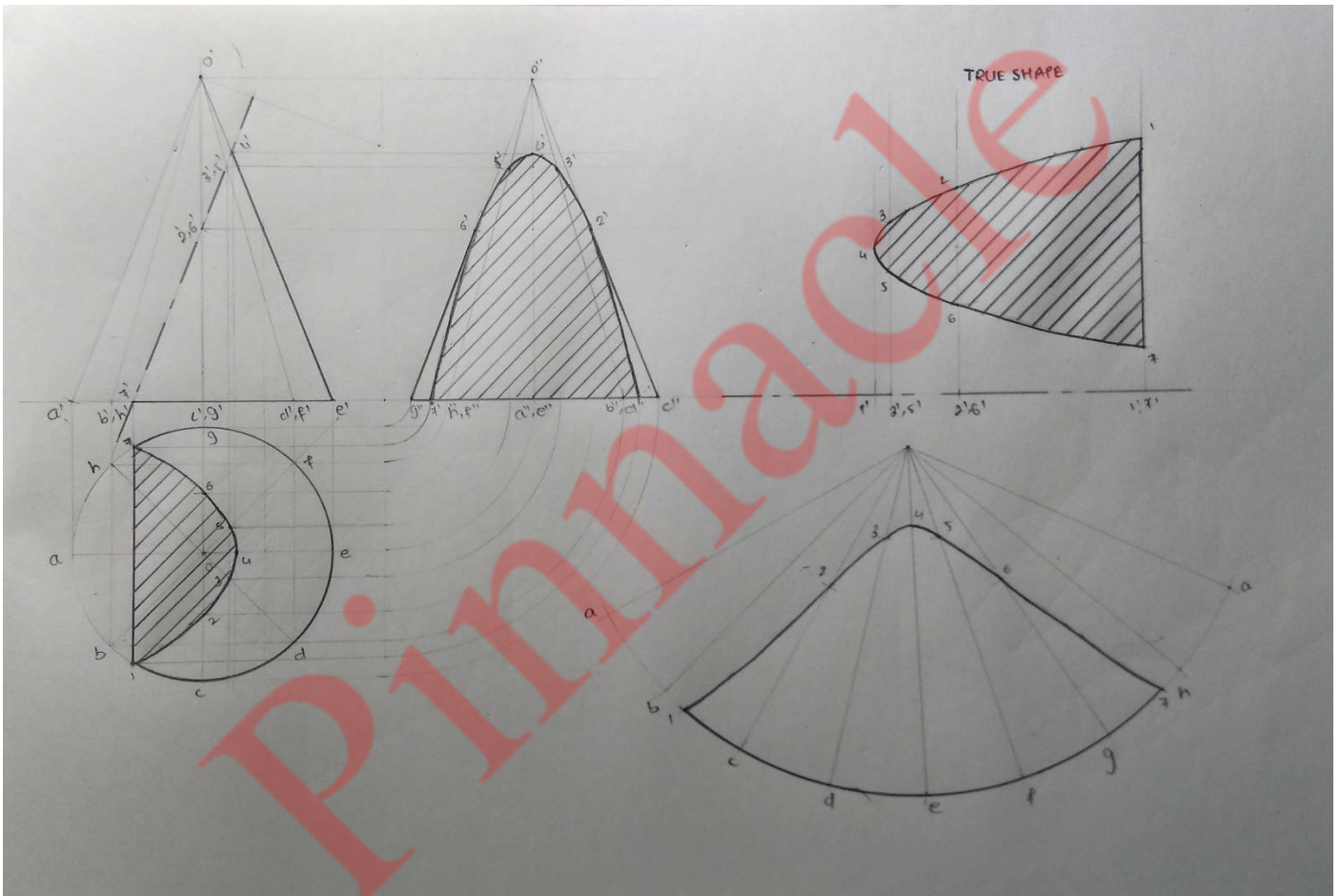

Q.6 (a) The T.V. of the line AB measures 60 mm and is inclined at  $56^\circ$  to the XY line. Point A is 10mm above the H.P. and 20 mm in front of the V.P. Point B is 45 mm above H.P. and in front of the V.P. Draw the projection of line AB. (09)

SOL:

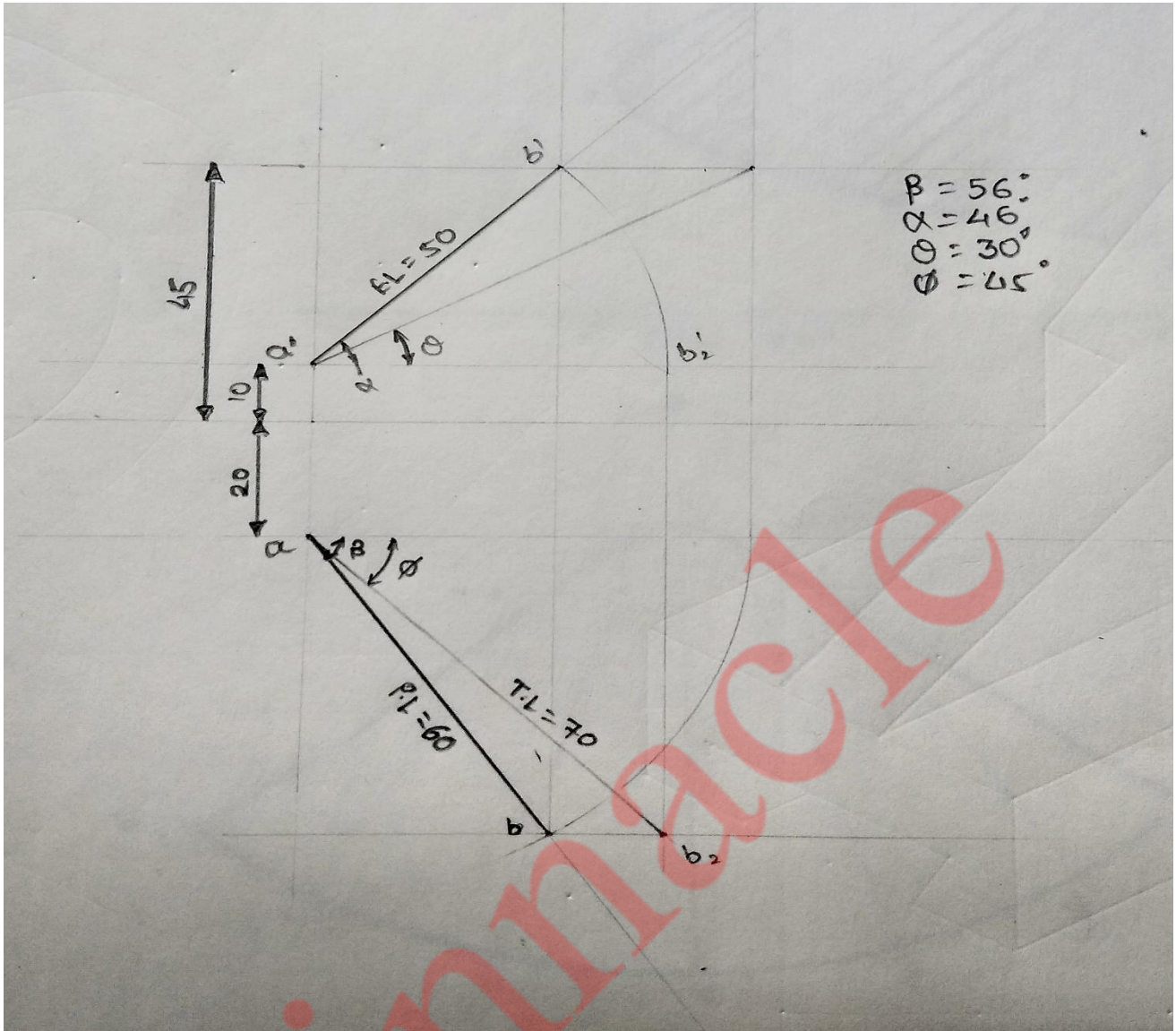

Q.6 (b) Figure shows two views of an object. Draw its isometric view with 'O' as origin. (06)

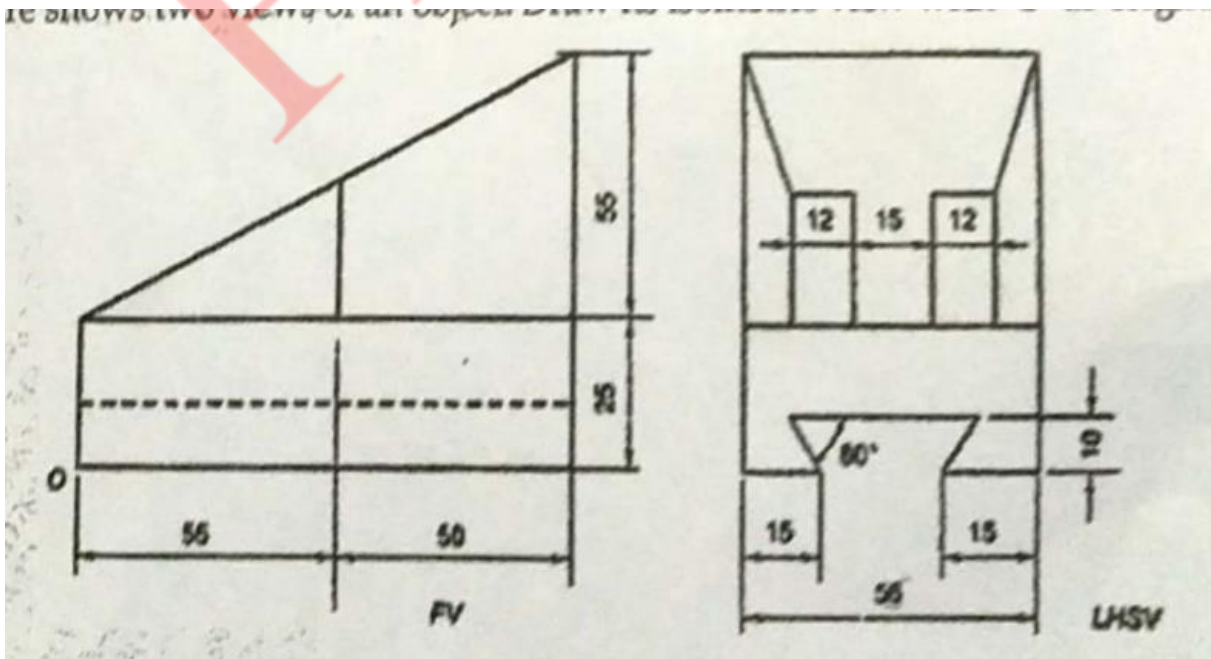

OUR CENTERS :

KALYAN | DOMBIVLI | THANE | NERUL | DADAR

Contact - 9136008228

SOL:

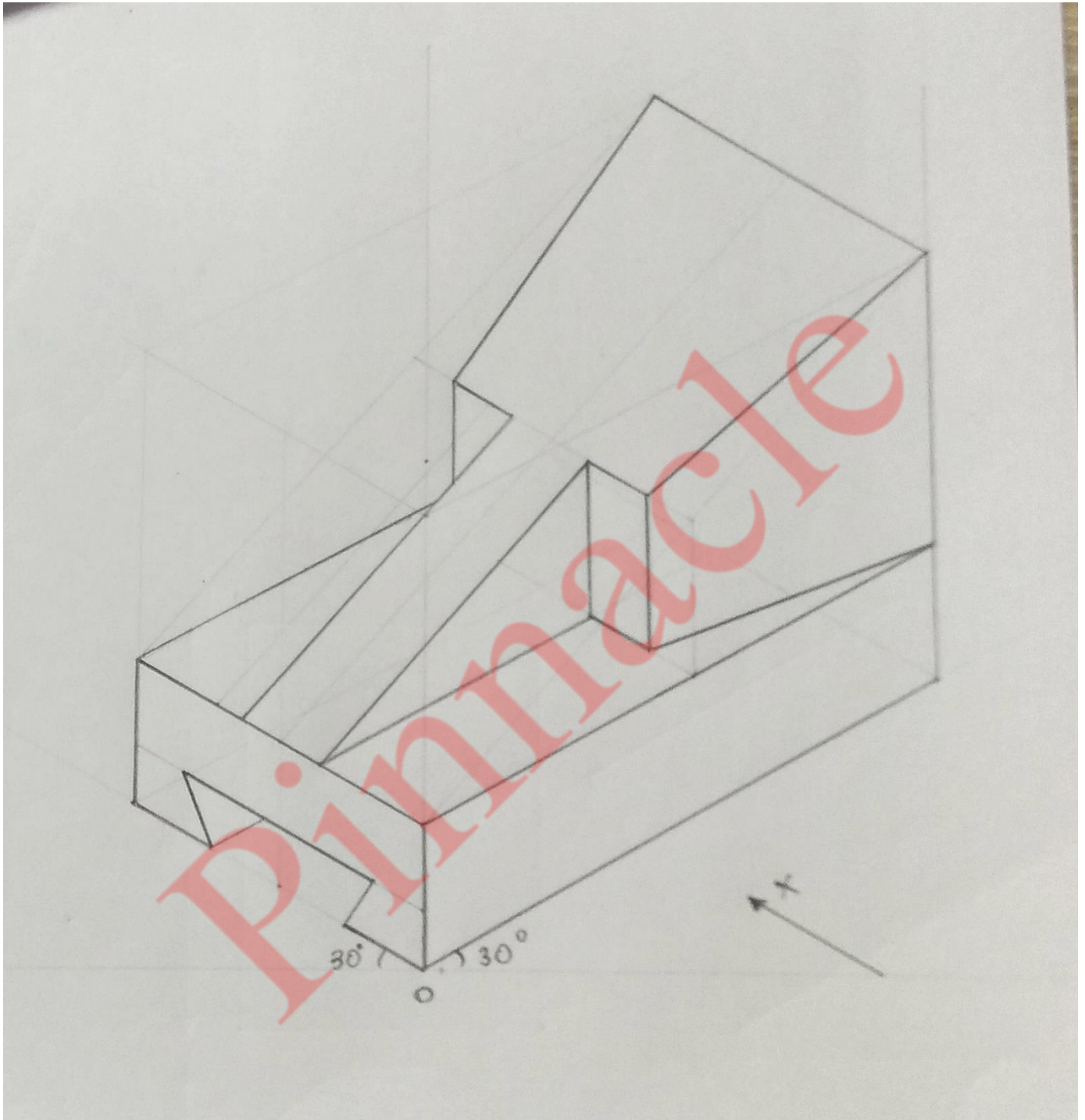

**OUR CENTERS :**

**KALYAN | DOMBIVLI | THANE | NERUL | DADAR**

**Contact - 9136008228**